



PUBLIC ADDRESS SYSTEM

OPERATION MANUAL

TI-60B
TI-120B
TI-240B
TI-350B

5 ZONE MIXER AMPLIFIER



Please follow the instructions in this manual to obtain the optimum results from this unit. We also recommend that you keep this manual handy for future reference.

TABLE OF CONTENTS

1. SAFETY PRECAUTIONS	3
2. GENERAL DESCRIPTION	5
3. FEATURES	5
4. NOMENCLATURE AND FUNCTIONS	
4.1 Front Panel(2U)	6
4.2 Rear Panel(2U).....	7
4.3 Front Panel(3U)	8
4.4 Rear Panel(3U).....	9
5. CONNECTIONS	
5.1. Speaker Connections	10
5.2. XLR Connections	10
6. MACHINE OPERATION	11
7. APPLICATIONS	12
8. BLOCK DIAGRAM	14
9.SPECIFICATIONS	15
10.DIMENSIONAL DIAGRAM	17

1. SAFETY PRECAUTIONS

- Be sure to read the instructions in this section carefully before use.
- Make sure to observe the instructions in this manual as the conventions of safety symbols and messages regarded as very important precautions are included.
- We also recommend you keep this instruction manual handy for future reference.

Safety Symbol and Message Conventions

Safety symbols and messages described below are used in this manual to prevent bodily injury and property damage which could result from mishandling. Before operating your product, read this manual first and understand the safety symbols and messages so you are thoroughly aware of the potential safety



WARNING

Indicates a potentially hazardous situation which, if mishandled, could result in death or serious personal injury.



CAUTION

Indicates a potentially hazardous situation which, if mishandled, could result in moderate or minor personal injury, and/or property damage.



WARNING

When Installing the Unit

- Do not expose the unit to rain or an environment where it may be splashed by water or other liquids, as doing so may result in fire or electric shock.
- Use the unit only with the voltage specified on the unit. Using a voltage higher than that which is specified may result in fire or electric shock.
- Do not cut, kink, otherwise damage nor modify the power supply cord. In addition, avoid using the power cord in close proximity to heaters, and never place heavy objects -- including the unit itself -- on the power cord, as doing so may result in fire or electric shock.
- Be sure to replace the unit's terminal cover after connection completion. Because high voltage is applied to the speaker terminals, never touch these terminals to avoid electric shock.
- Be sure to ground to the safety ground (earth) terminal to avoid electric shock. Never ground to a gas pipe as a catastrophic disaster may result.
- Avoid installing or mounting the unit in unstable locations, such as on a rickety table or a slanted surface. Doing so may result in the unit falling down, causing personal injury and/or property damage.

When the Unit is in Use

- Should the following irregularity be found during use, immediately switch off the power, disconnect the power supply plug from the AC outlet and contact your nearest **ITC** dealer. Make no further attempt to operate the unit in this condition as this may cause fire or electric shock.
 - If you detect smoke or a strange smell coming from the unit.
 - If water or any metallic object gets into the unit
 - If the unit falls, or the unit case breaks
 - If the power supply cord is damaged (exposure of the core, disconnection, etc.)
 - If it is malfunctioning (no tone sounds.)
- To prevent a fire or electric shock, never open nor remove the unit case as there are high voltage components inside the unit. Refer all servicing to your nearest **ITC** dealer.
- Do not place cups, bowls, or other containers of liquid or metallic objects on top of the unit. If they accidentally spill into the unit, this may cause a fire or electric shock.
- Do not insert nor drop metallic objects or flammable materials in the ventilation slots of the unit's cover, as this may result in fire or electric shock.

1. SAFETY PRECAUTIONS

CAUTION

When Installing the Unit

- Never plug in nor remove the power supply plug with wet hands, as doing so may cause electric shock.
- When unplugging the power supply cord, be sure to grasp the power supply plug; never pull on the cord itself. Operating the unit with a damaged power supply cord may cause a fire or electric shock.
- When moving the unit, be sure to remove its power supply cord from the wall outlet. Moving the unit with the power cord connected to the outlet may cause damage to the power cord, resulting in fire or electric shock. When removing the power cord, be sure to hold its plug to pull.
- Do not block the ventilation slots in the unit's cover. Doing so may cause heat to build up inside the unit and result in fire.
- Avoid installing the unit in humid or dusty locations, in locations exposed to the direct sunlight, near the heaters, or in locations generating sooty smoke or steam as doing otherwise may result in fire or electric shock.

When the Unit is in Use

- Do not place heavy objects on the unit as this may cause it to fall or break which may result in personal injury and/or property damage. In addition, the object itself may fall off and cause injury and/or damage.
- Make sure that the volume control is set to minimum position before power is switched on. Loud noise produced at high volume when power is switched on can impair hearing.
- Do not operate the unit for an extended period of time with the sound distorting. This is an indication of a malfunction, which in turn can cause heat to generate and result in a fire.
- Contact your **ITC** dealer as to the cleaning. If dust is allowed to accumulate in the unit over a long period of time, a fire or damage to the unit may result.
- If dust accumulates on the power supply plug or in the wall AC outlet, a fire may result. Clean it periodically. In addition, insert the plug in the wall outlet securely.
- Switch off the power, and unplug the power supply plug from the AC outlet for safety purposes when cleaning or leaving the unit unused for 10 days or more. Doing otherwise may cause a fire or electric shock.

An all-pole mains switch with a contact separation of at least 3 mm in each pole shall be incorporated in the electrical installation of the building.

2. GENERAL DESCRIPTION

ITC series of public address mixer amplifiers have power ratings from 60 to 350 watts and feature optional balanced MIC inputs, AUX level inputs and EMC (priority) level inputs.

3. FEATURES

- Rated outputs from 60W to 120W and 240W and 350W.
- 100V/70V line transformer-isolated speaker outputs, low impedance 4-16 ohms speaker outputs.
- One EMC priority input and one line input.
- Two stereo aux input and two line input.
- Two balanced line inputs and three balanced microphone inputs
- EMC input with priority over all other inputs except MIC 1.
- AUX, MIC, Bass, Treble volume control.
- MIC 1 mute level control.
- Power and protection indicators and 6 output level meters.

4. NOMENCLATURE AND FUNCTIONS

4.1 FRONT PANEL(2U)

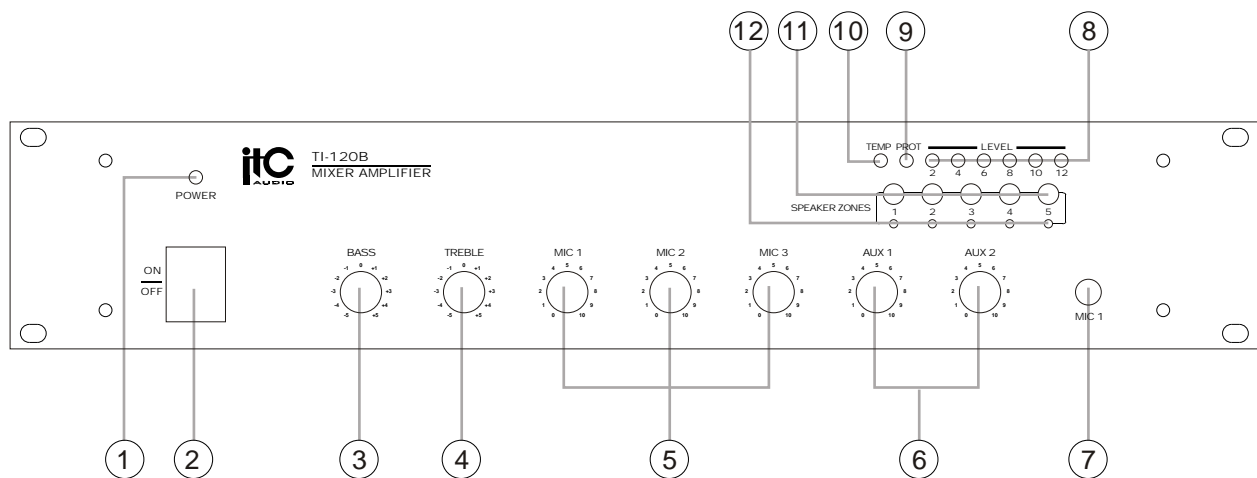

- | | |
|---|---|
| <p>1. POWER
Power indicator</p> <p>2. POWER SWITCH
On top of the opening Power
Press the end, power shut down</p> <p>3. BASS
Adjust bass response. Rotate clockwise to increase bass output and anticlockwise to reduce it.</p> <p>4. TREBLE
Adjust treble response. Rotate clockwise to increase treble output and anticlockwise to reduce it.</p> <p>5. MIC1 \ MIC2 \ MIC3
MIC volume control (MIC1/MIC2/MIC3)</p> | <p>6. AUX1 \ AUX2
AUX volume control(AUX 1/AUX 2)</p> <p>7. MIC1
MIC1 input 6.3 Microphone jack input</p> <p>8. LEVEL INDICATORS
Level meters 6 output level indicators</p> <p>9. PROT
Protection indicator</p> <p>10. TEMP
Temperature indicator</p> <p>11. SPEAKER ZONE(1~5)
Speaker zone(1~5) button control</p> <p>12. SPEAKER ZONE(1~5)
Speaker zone(1~5) indicator</p> |
|---|---|

4.2 REAR PANEL(2U)

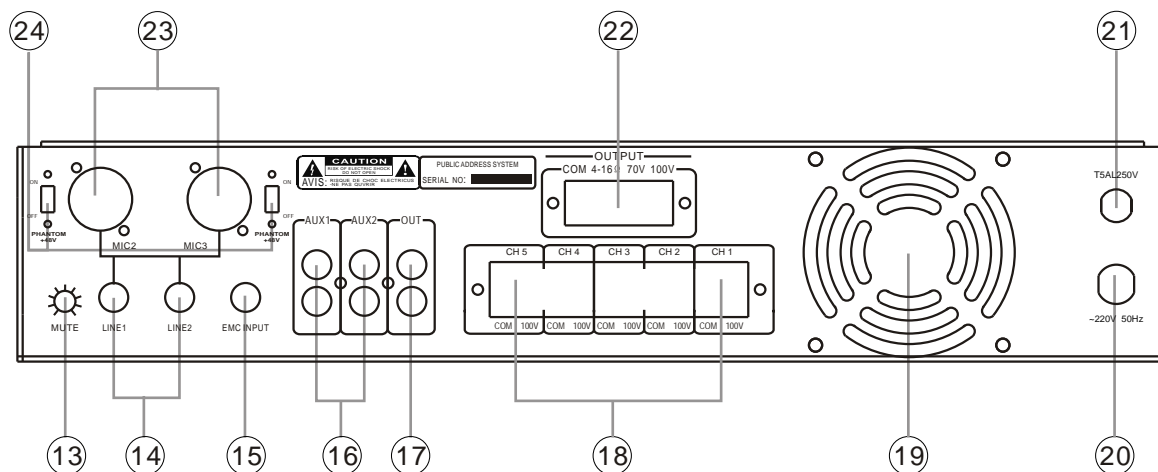

13.MUTE

Mute Microphone 1 mute level control

14.LINE1 \LINE2

Line Balanced inputs

15.EMC

EMC Input Fire alarm signal input

16.AUX1/AUX2

Auxiliary input jack, Non-equilibrium of connecting peripherals signal

17.OUT

Line output, Non-equilibrium type, the output of all input signals.

18.(1~5) ZONE OUTPUT TERMINAL (100V)

Connecting speakers

19.COOLING FANS

20.~ 220V+/50Hz AC POWER INPUT

21.AC FUSE

22.SPEAKER TERMINALS

Connectors for 4-16 ohms or 70V and 100V speaker

23.MIC2 \ MIC3

MIC balanced inputs

24.+48V PHANTOM SWITCHES

4. NOMENCLATURE AND FUNCTIONS

4.3 FRONT PANEL(3U)

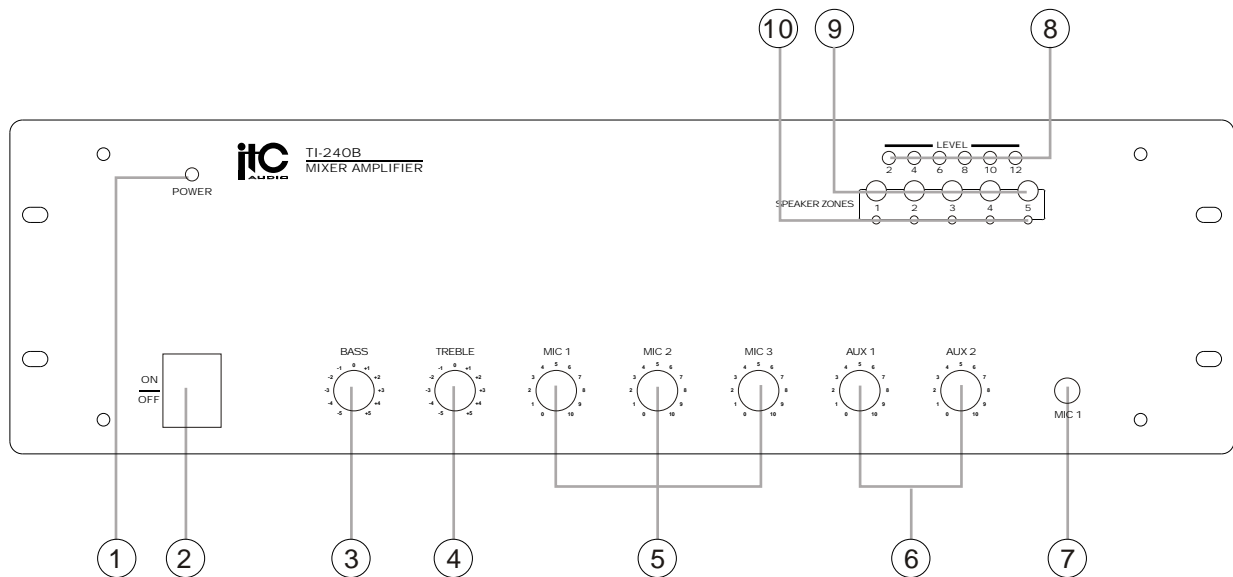

- 1. POWER**
Power indicator
- 2. POWER SWITCH**
On top of the opening Power
Press the end, power shut down
- 3. BASS**
Adjust bass response. Rotate clockwise to increase bass output and anticlockwise to reduce it.
- 4. TREBLE**
Adjust treble response. Rotate clockwise to increase treble output and anticlockwise to reduce it.
- 5. MIC1 \ MIC2 \ MIC3**
MIC volume control (MIC1/MIC2/MIC3)
- 6. AUX1 \ AUX2**
AUX volume control(AUX 1/AUX 2)
- 7. MIC1**
MIC1 input 6.3 Microphone jack input
- 8. LEVEL INDICATORS**
Level meters 6 output level indicators
- 9. SPEAKER ZONE(1~5)**
Speaker zone(1~5) button control
- 10..SPEAKER ZONE(1~5)**
Speaker zone(1~5) indicator

4.4 REAR PANEL(3U)

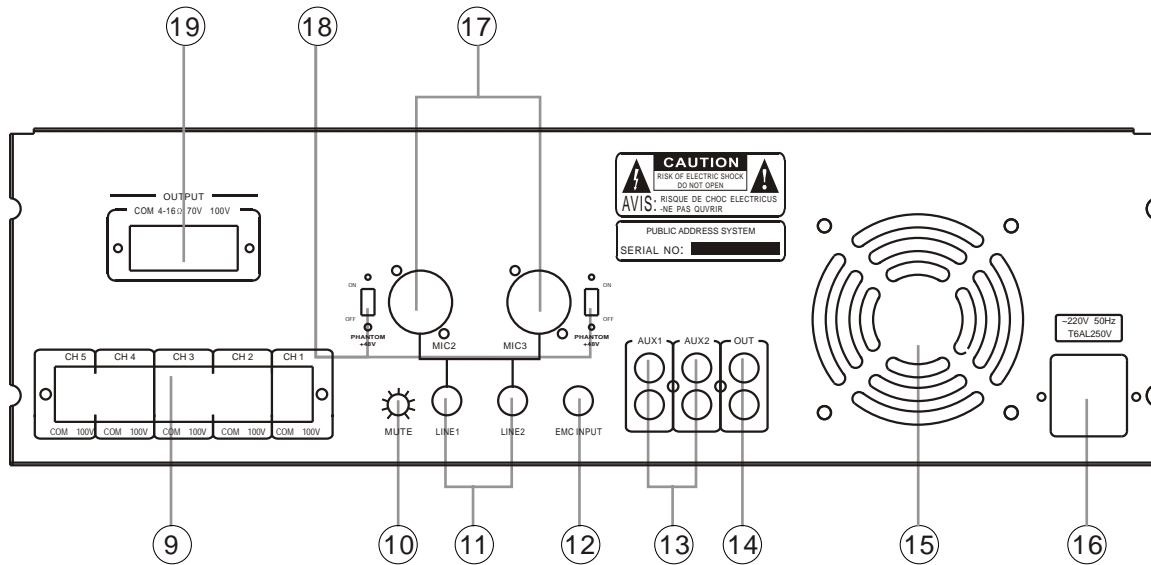

9. (1~5) ZONE OUTPUT TERMINAL (100V)

Connecting speakers

10.MUTE

Mute Microphone 1 mute level control

11.LINE1 \LINE2

Line Balanced inputs

12.EMC

EMC Input Fire alarm signal input

13.AUX1/AUX2

Auxiliary input jack, Non-equilibrium of connecting peripherals signal

14.OUT

Line output, Non-equilibrium type, the output of all input signals.

15.COOLING FANS

16.~ 220V+/50Hz AC POWER INPUT

17.MIC2 \ MIC3

MIC balanced inputs

18.+48V PHANTOM SWITCHES

19.SPEAKER TERMINALS

Connectors for 4-16 ohms or 70V and 100V speaker

5. CONNECTIONS

5.1 SPEAKER CONNECTIONS

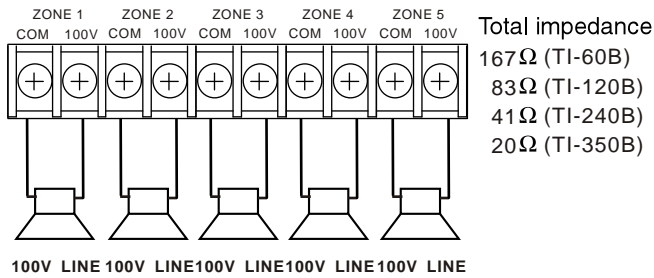
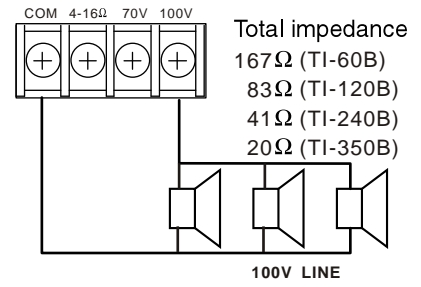
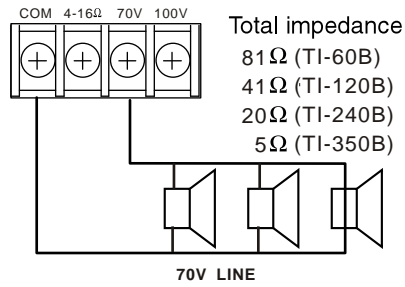
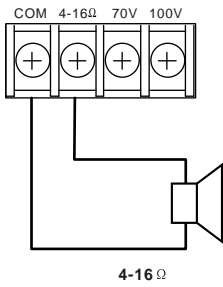

Total impedance
 167 Ω (TI-60B)
 83 Ω (TI-120B)
 41 Ω (TI-240B)
 20 Ω (TI-350B)

Notes

- Both the 4 – 16 Ω and 100 V terminals cannot be used at the same time.
- Impedances indicated in the figures represent the total speaker system (load) impedances.

⚠ WARNING

Be sure to attach the supplied terminal cover after connection completion. Because high voltage is applied to the speaker terminals, never touch these terminals to avoid electric shock.

5.2 XLR CONNECTIONS

Combined XLR (female)/phone jack connectors.

Usable connectors and plugs

- XLR type male connector

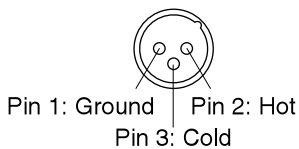

- Phone plug

Sleeve: Ground

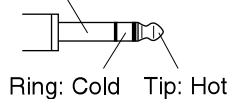

6. MACHINE OPERATION

OPERATION ATTENTION

The four output connectors only can choose two connectors work together. If voltage is 70V/100V, the speakers must be with transformer and make sure the total power wattage of speaker is 15% less than the power wattage of amplifier.

MUTE FUNCTION

MIC 1 with the first priority over other inputs, the adjustment should be kept within 0-30db with the mute connector, 30db is the original setting.

GUIDANCE OF EXCLUDING ERRORS

Phenomena	Cause
All the wires are connected well but no voice output	1 No power or wrong plug connection 2 Fuse is burned 3 Volume is town off 4 No input signal
Power on but alarming signal	1 Overloading or short circuit 2 Voltage is not stable, too high or low
No voice output in normal condition	1 Machine is in protection condition in case of high temperature 2 Wrong wire connection

7. APPLICATIONS

TI-60B/120B REAR PANEL CONNECTIONS

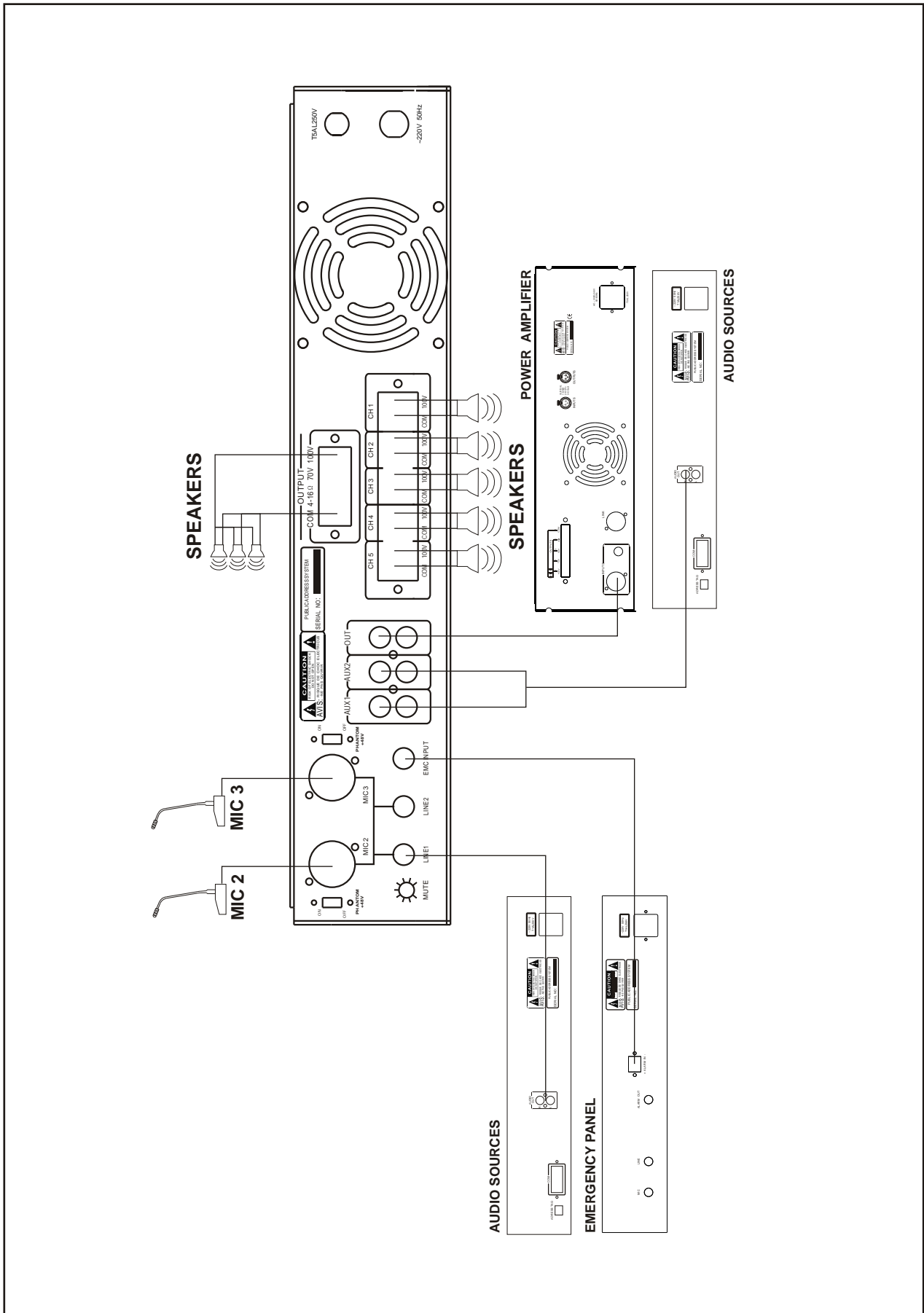

TI-240B/350B REAR PANEL CONNECTIONS

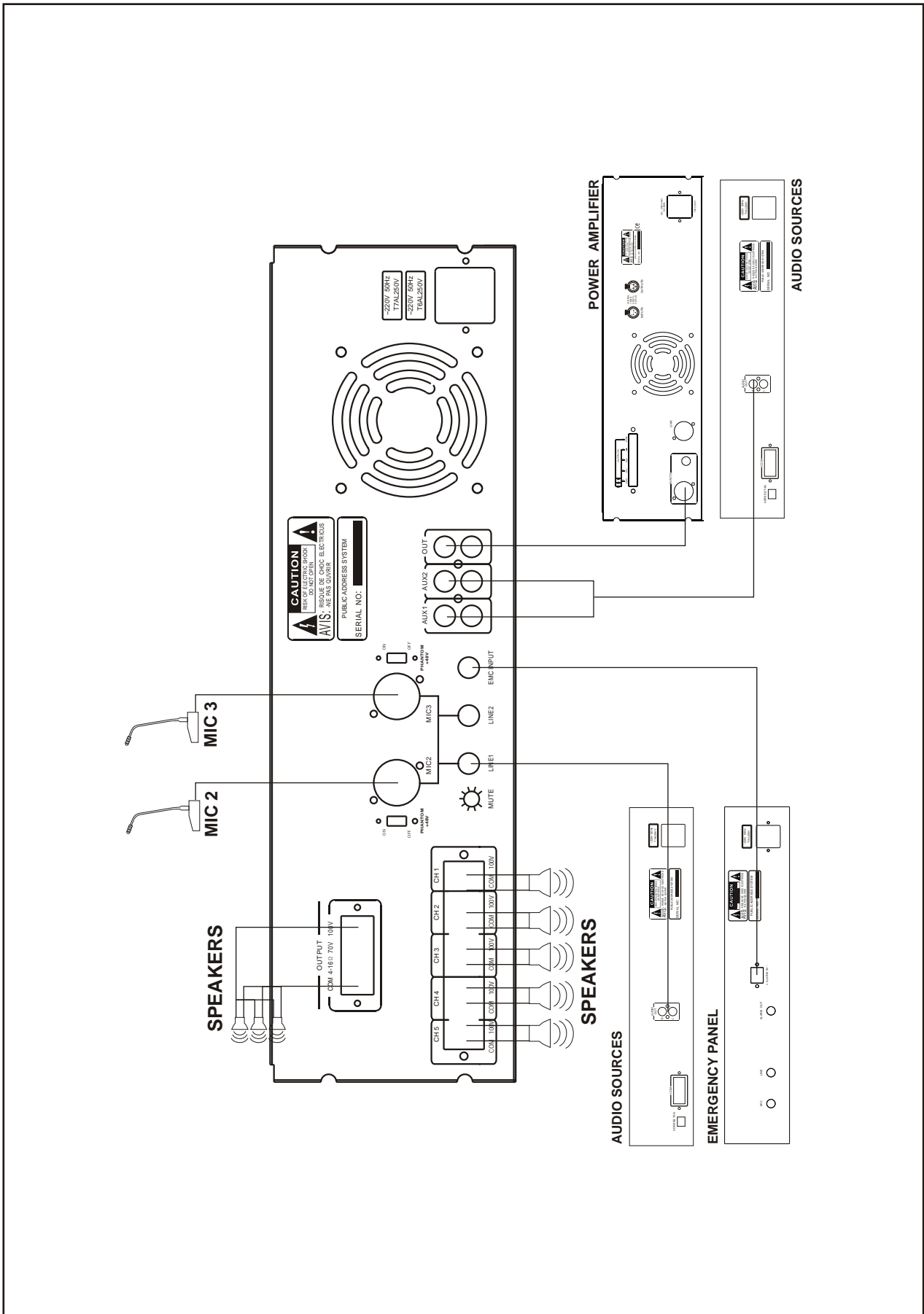

8. BLOCK DIAGRAM

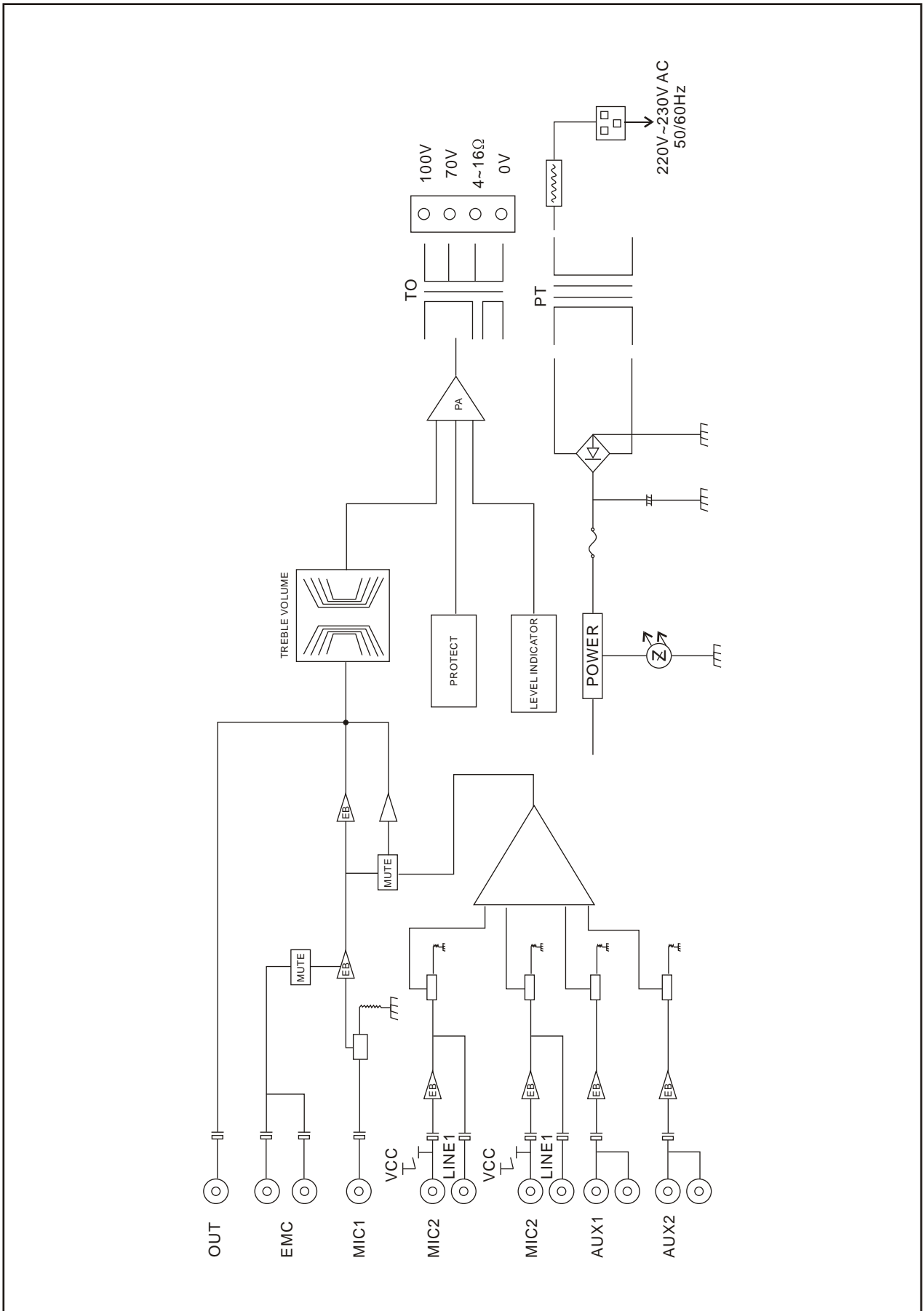

9. SPECIFICATIONS

MIXER AMPLIFIER(2U)		
MODEL	TI-60B	TI-120B
RATED POWER OUTPUT	60W	120W
SPEAKER OUTPUTS	4~16 Ω ,70V/100V	
INPUT	MIC 1、 2、 3: 5mv/600 Ohms,Balanced/Unbalanced AUX 1、 4: 250mV/15KOhms, Unbalanced EMC 1、 2 : 250mV/15KOhms, Unbalanced	
PHANTOM	48V	
TONE	Bass:±10dB at 100Hz Treble:±10dB at 10KHz	
FREQUENCY RESPONSE	50Hz~15KHz	
S/N RATIO	MIC 1、 2、 3: 66dB;AUX 1、 2: 80dB	
T.H.D	Less than 1% at 1KHz,1/3 rated power	
CROSSTALK	MIC : 80dB;AUX 85dB	
MUTING FUNCTION	MIC 1 over other input signals with 0~30dB attenuation EMC 1 ove all inputs except MIC 1	
CONTROLS	Individual gain controls, power switch	
INDICATORS	Power LED,LED level meter,protect	
PROTECTION	AC fuse, short-circuit and high temperature	
POWER REQUIREMENTS	~220V±10%/50Hz	
POWER CONSUMPTION	100W	200W
DIMENSION(mm)	484X360X88	
NET WEIGHT	7.72Kg	9.94Kg
GROSS WEIGHT	8.92Kg	10.14Kg

SPECIFICATIONS

MIXER AMPLIFIER(3U)		
MODEL	TI-240B	TI-350B
RATED POWER OUTPUT	240W	350W
SPEAKER OUTPUTS	4~16 Ω ,70V/100V	
INPUT	MIC 1、 2、 3: 5mv/600 Ohms,Balanced/Unbalanced AUX 1、 4: 250mV/15KOhms, Unbalanced EMC 1、 2 : 250mV/15KOhms, Unbalanced	
PHANTOM	48V	
TONE	Bass:±10dB at 100Hz Treble:±10dB at 10KHz	
FREQUENCY RESPONSE	50Hz~15KHz	
S/N RATIO	MIC 1、 2、 3: 66dB;AUX 1、 2: 80dB	
T.H.D	Less than 1% at 1KHz,1/3 rated power	
CROSSTALK	MIC : 80dB;AUX 85dB	
MUTING FUNCTION	MIC 1 over other input signals with 0~30dB attenuation EMC 1 ove all inputs except MIC 1	
CONTROLS	Individual gain controls, power switch	
INDICATORS	Power LED,LED level meter,protect	
PROTECTION	AC fuse, short-circuit and high temperature	
POWER REQUIREMENTS	~220V ± 10%/50Hz	
POWER CONSUMPTION	400W	500W
DIMENSION(mm)	484X447X132	
NET WEIGHT	17.4Kg	19.12Kg
GROSS WEIGHT	18.9Kg	20.62Kg

10. DIMENSIONAL DIAGRAM

TI-60B/120B UNIT :mm

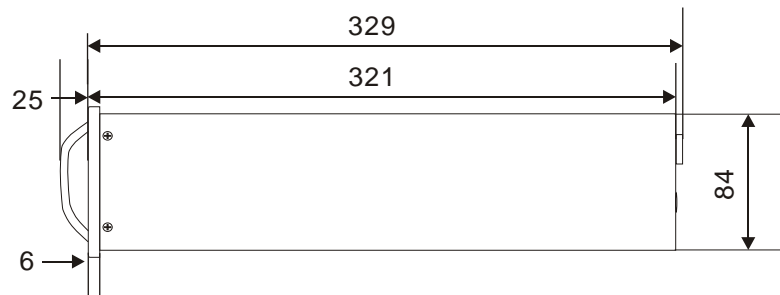
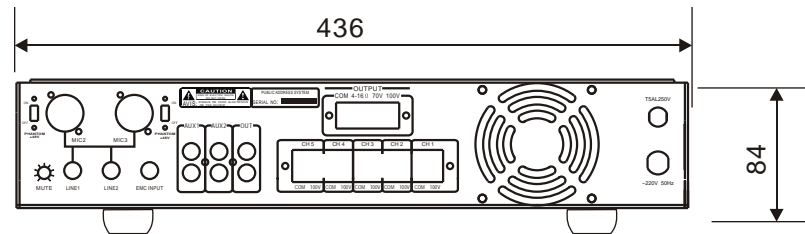
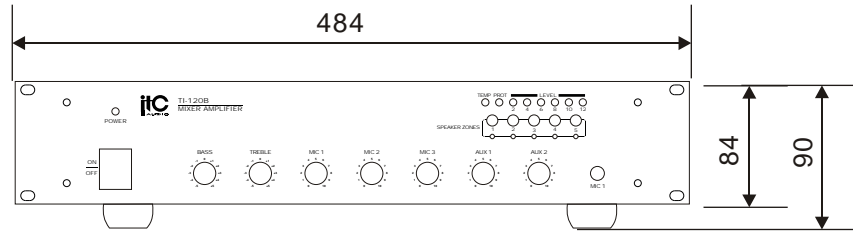

Keep the unit's all sides over 10 cm away from objects that may obstruct air flow to prevent the unit's internal temperature rise.

UNIT :mm

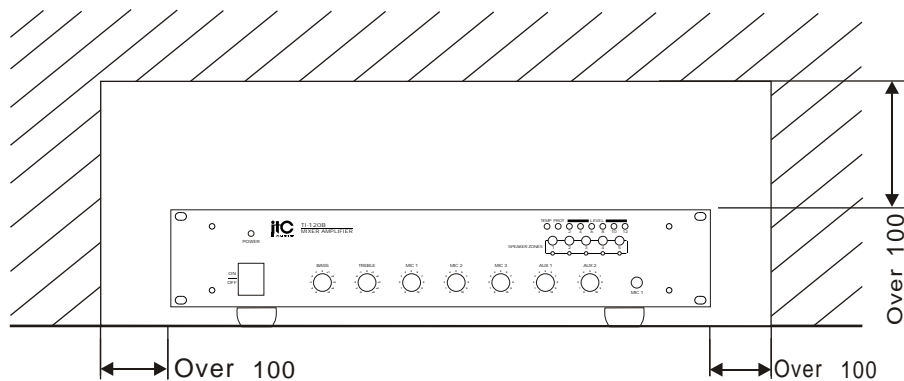

DIMENSIONAL DIAGRAM

TI-240B/350B UNIT :mm

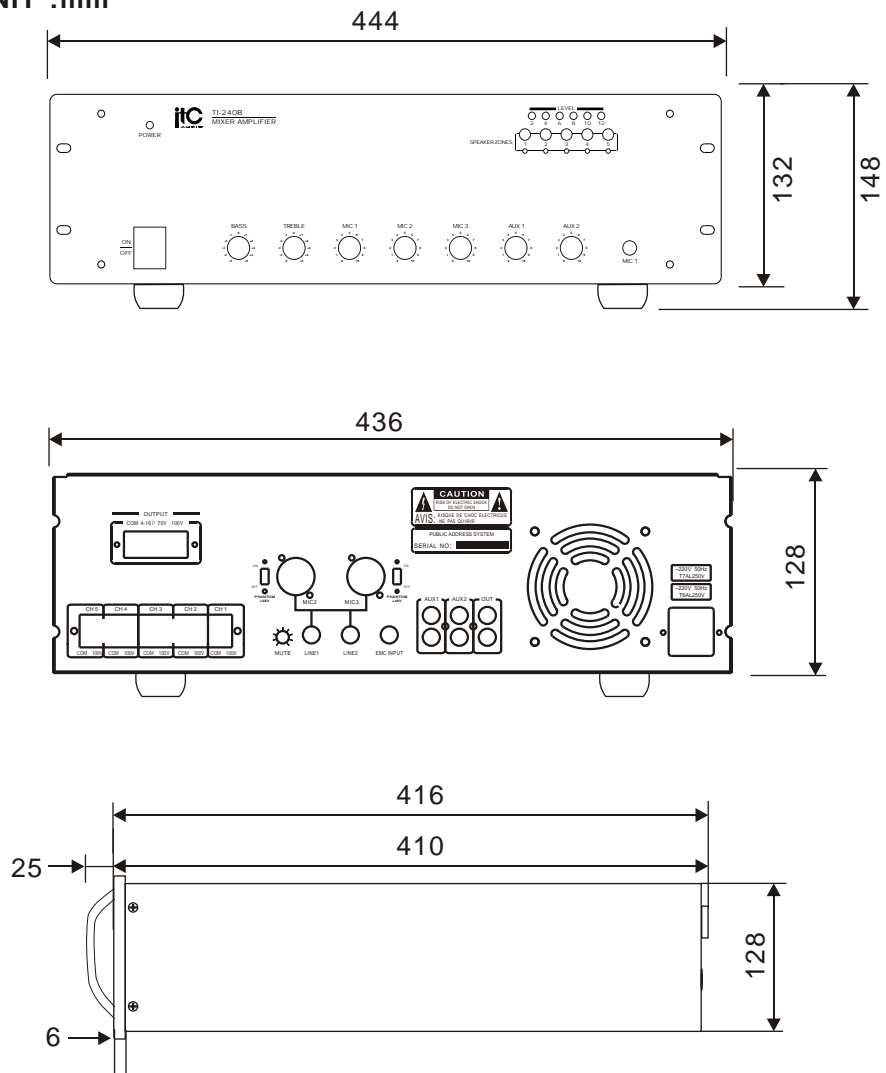

Keep the unit's all sides over 10 cm away from objects that may obstruct air flow to prevent the unit's internal temperature rise.

UNIT :mm

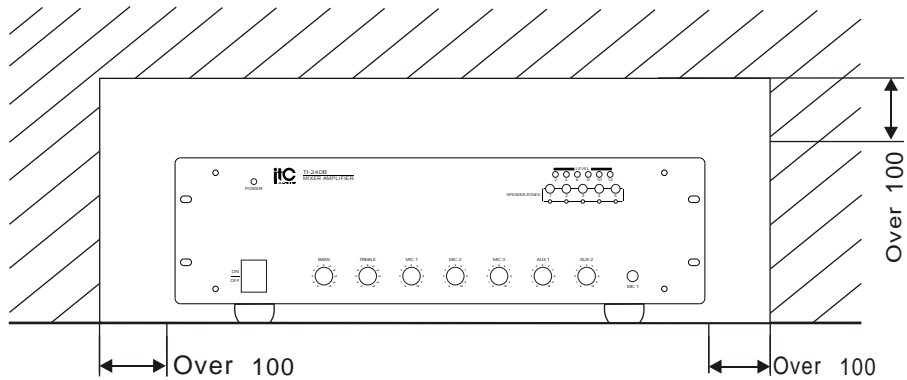

PUBLIC ADDRESS SYSTEM



Guangzhou ITC Electronic Technology Limited
[Http://www.itc-pa.com.cn](http://www.itc-pa.com.cn)