

16 Zone Voice Evacuation VA & PA Sound System

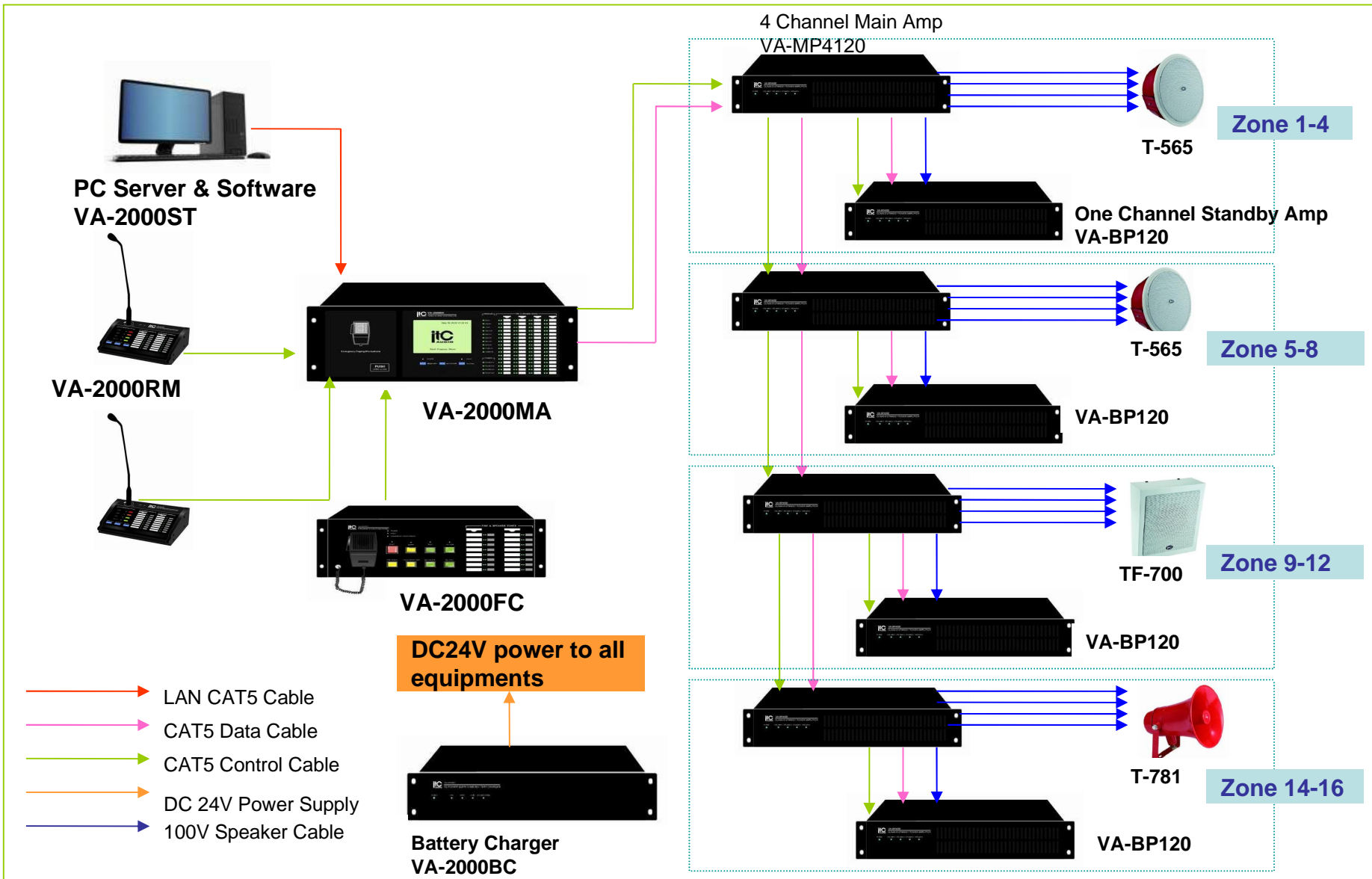

Voice Evacuation System Features



- LAN Network System for lowest wiring cost and highest reliability.
- Fully accordance with EN54-16 voice alarm control and indicating equipments.
- Zone Module design of flexible zone configuration from 4 to 64 zones.
- User friendly by touch screen control.
- Permanent supervision from microphone, source, amplifier, AC & DC to speaker line, all working status and failure will be shown and signal a fault indication.
- 4 voice alarm message simultaneously distributed to 64 zones.
- Switching power technology high impedance Class-D power amplifier and standby amplifier.
- 22 channel inputs of maximum capacity: 4 alarm messages, 4 commercial message, 2 aux, 1 PC input, 9 remote mic, 1 emergency mic and 1 fireman mic.
- 256 fault logging history records.
- Open protocol to inter-work with third party systems.
- External trigger from fire detection system or pus buttons to active 8 voice messages for pre-set zones.
- Remote control & maintenance in the LAN network system.
- Multi alarm modes: all zones, group zones, neighbourhood zones and separate zone.
- Integrate with PA system includes audio matrix system, weekly program timer and power sequencer.
- System zone capacity expansion up to 512 zones.

VA-2000MA Compliance with EN54-16

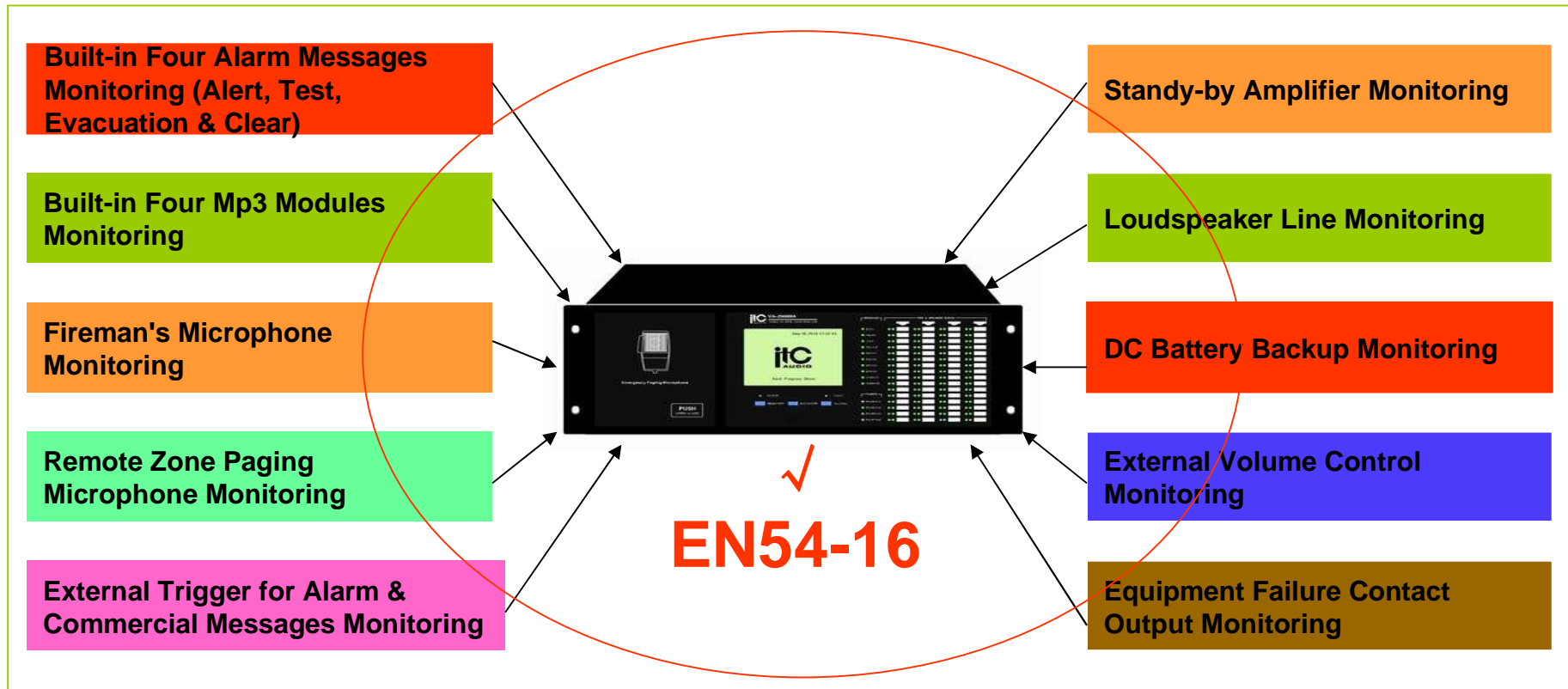

VA-2000MA Compliance with EN54-16



- A fault on the mic capsule or on the mic line will immediately signal a fault indication.
- Both alarm & commercial message module's online status will be monitored and displayed.
- These 8 trigger coming from a fire detection system or from external push-buttons, are used to trigger the alarm and commercial message to pre-set zone. These lines failure also will signal a fault indication.
- The DC24V battery charger automatically supports uninterrupted operation for 30 minutes when AC fails. AC and DC status will be shown and monitored.
- The EN54-16 recommend at least one standby amplifier will be automatically switched on when one of the eight duty amplifiers failed. The system provide 3 amplifier standby modes: one backup one, one backup two and one backup four. The duty amplifier and standby amplifier working status both will be shown and monitored. An automatically changeover will be enabled when duty amplifier is in failure.
- All loudspeaker lines are continuously monitored. The monitoring is based on impedance measurement of loudspeaker lines.
- The system can store up to 256 fault messages indicating date and time of occurrence in a non-volatile error.

16 Zone EVAC Sound System Equipment List



S.N.	Name	Model	Qty
1	PC & System Software	VA-2000ST	1
2	Voice Alarm Controller, 16 zones	VA-2000MA	1
3	Fireman Microphone	VA-2000FC	1
4	Remote Paging Microphone	VA-2000RM	2-9
5	Class-D 4 Channel Power Amplifier, 4 × 120W	VA-MP4120	4
6	Class-D Standby One Channel Power Amplifier, 120W	VA-BP120	4
7	Battery Charger	VA-2000BC	1
8	Fire-proof Ceiling Speaker, 6W	T-565	128
9	Fire-proof Wall Mount Speaker, 6W	TF-700	64
10	Explosion-proof Horn Speaker, 15W	T-781	25

The voice alarm system solution is specially designed for high reliable applications like intelligent building, shopping mall, government office, stadium, train station, university and airport.

The system is fully compliance with EN54-16 voice alarm control and indication regulations, it is the most reliable system up to today, so each module's working status and failure will be shown and signal an indication, so the system can be operated free of worry even under extreme severe conditions.

VA-2000ST is a remote setting and management software, after configuration, the setting shall be downloaded to the master controller, then the system could be work alone without the PC and software. The software is designed to compatible with Windows XP/2000/Windows 7. The software also could be regarded as a remote operator within a LAN network for maintenance far from the control room.

VA-2000MA is the master controller of this system, it is a zone module design from minimum 4 zones to maximum 64 zones. There are 4 voice alarm messages could be simultaneously distributed to the pre-set or manual selected zones. Another 4 commercial business messages could be triggered by remote push buttons. Both of these 8 messages are designed by Mp3 storage format, so the end-user could download user-recorded messages into this system easily. Total nine remote paging mic inputs for different size of paging system, a fireman mic control panel input plus the built-in emergency microphone

attributed to the eleven levels of different prioritized paging system. Two external aux inputs and one PC aux input let this EVAC system included PA system, moreover, a built-in weekly timer provide a convenient tool for program timing task. All of the module status and failure indication could be tracked down through the LCD English display. Emergency mic announcement, manual voice alarm operation and manual music broadcast, fire alarm system restore all could be done on this controller. There are 16 zone fire alarm module on the rear panel to receive contact signal from fire detection system. Line output to amplifier is designed by RJ45 port, each CAT5 cable could transmit 4 pairs of control & audio data to 4 power amplifiers, the communication distance could be around 1kms, the communication bus control & audio data could be hand-in-hand connected from one power amplifier to its neighborhood one. System fault and reset remote contact input are easy maintenance.

VA-2000FC is a 16 zone fireman control panel, it is built-in a hand clip emergency mic, fireman could broadcast live voice evacuation message at a remote fire center. It is power supplied and communicated with the master controller only by one CAT5 cable. There are voice alarm buttons for one-push voice alarm operation, these buttons are designed with cover ensure protection from unattended operation. Fireman control panel voice announcement with highest priority over other inputs except the emergency microphone built-in the controller.

VA-2000RM is a 16 zone remote paging microphone, it is directly connected to the master controller by CAT 5 cable, while DC 24V power supply is needed and communication distance up to 2kms. There could be 9 remote paging microphone input into the controller with different pre-set priorities. A simpler fireman remote paging mic and a business remote paging mic both are available. Excellent sound clearness and voice reduction.

VA-MP4120 is a Class-D 4 channel power amplifier for this EVAC system. We offer a wide range of power amplifier from single channel, two channels to four channels. Each channel have 120W, 240W, 350W and 500W options. These amplifiers are designed of latest switching power technology to ensure its reliability. The Class-D amplifier are high impedance 100V outputs to loudspeaker with line transformer. The power amplifier built-in speaker line supervision module to keep a constant line monitoring. A fault indication will be generated as soon as any speaker line is detected by impedance measurement. Moreover, the Class-D technology enhance the efficiency while reduce energy consumption.

VA-BP120 is a Class-D single channel standby amplifier for this EVAC system. The standby amplifier will be automatically backup when one of four the duty amplifier fails. We offer a wide range of power amplifier from single channel, two channels to four channels. Each channel have 120W, 240W, 350W and 500W options. These amplifiers are designed of latest switching power technology to ensure its reliability.

The Class-D amplifiers are of high impedance 100V output to loudspeaker with line transformer. The power amplifier built-in amplifier failure automatic changeover module. Moreover, the Class-D technology enhance the efficiency while reduce energy consumption.

T-565 is a fire-proof ceiling speaker specially designed for the EVAC system. The fireproof features include fire-proof metal enclosure and back cover, ceramic connector and fire-resistant cable. It is rated at 6W power output, 0.38W, 0.75W, 1.5W, 3W power taps are available. Spring clip mounting design for quick and safe installation.

TF-700 is a fire-proof wall mount speaker specially designed for the EVAC system. The fireproof features include fire-proof metal enclosure and back cover, ceramic connector and fire-resistant cable. It is rated at 6W power output, 0.75W, 1.5W, 3W power taps are available. Hole wall mounting design for quick and safe installation.

T-781 is a explosion-proof horn speaker specially designed for the EVAC system. The explosion-proof speaker are made of steel, it shall be installed in nuclear power station, coal mine and gas station. The speaker will not be incentive to let the electrical sound equipments got been exploded. It is rated at 15W. A wall mount bracket is provided for easy installation.