

Features

- Built-in 100v/70v transformer
- Pendant type loudspeaker
- 5" full range speaker driver
- Power output 6W @100V
- ABS enclosure and metal bracket

Description

The T-200 is a pendant speaker built-in 70v/100v transformer. The 70v/100v transformer technique reduces line losses on longer distance and allows easy parallel connection of multiple loudspeakers.

The built-in 5" full range speaker driver is designed of wide frequency response 130-14kHz, the rated power output 6W could meet different applications varies from room size and ambient noise surroundings.

The ABS enclosure and metal bracket are of white color. Easy and secure wall mount installation through the supplied mounting bracket.

It is ideal choice for industrial and commercial applications in the outdoor area of train station, shopping mall, parking area and factory where background music and paging is needed.



Specification

Model	T-200
Power Taps @100V	6W
Power Taps @70V	3W
Impedance	Black: Com Red:1.7K Ω
SPL(1W/1M)	91dB \pm 3dB
Max. SPL (Rated W/1M)	99dB
Frequency Response (-10dB)	130-14KHz
Finish	Baffle: ABS, White Grille: ABS, White
Speaker Driver	5" \times 1
Dimensions	205 \times 205mm
Weight	1.1kg
Mounting	With mounting bracket fixed by scre

Appearance:

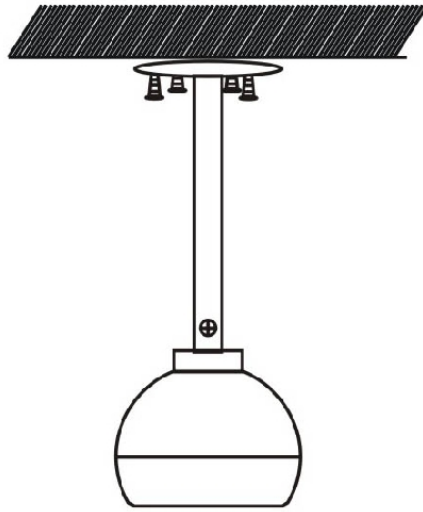
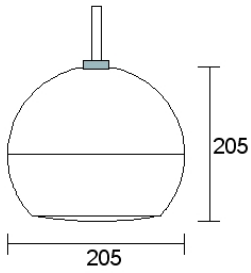

Frequency Response

